

SD38

Low profile metalized shielded drum core power inductors

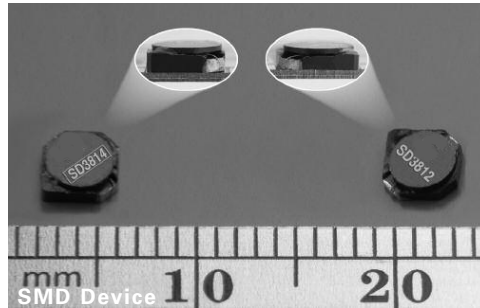

Applications

- Mobile phones
- Digital cameras
- Media players
- Small LCD displays
- LED driver and LED flash circuits
- Hard disk drives
- LCD Backlighting

Environmental data

- Storage temperature range (component): -40 °C to +125 °C
- Operating temperature range: -40 °C to +125 °C (ambient, plus self-temperature rise)
- Solder reflow temperature: STD-020 (latest revision) compliant

Product features

- 3.8 mm x 3.8 mm shielded drum cores available 1.2 mm and 1.4 mm heights
- Current range from 0.1 A to 4 A
- Inductance range from 0.47 uH to 680 uH
- Ferrite shielded, low EMI
- Ferrite core material

RoHS



Powering Business Worldwide

Discontinued, Effective July 2016 (SD3812) and August 2016 (SD3814) or until inventory is depleted. Please review MPI4012-V2, SD14, or MPI2512-V2 as an alternate replacement.

Product specifications

Part Number	Rated Inductance (μH)	OCL (1) +/-15% (μH)	Part Marking Designator	Irms (2) (A)	Isat (3) (A)	DCR (4) (Ω) Typ.	Volt (5) u-sec Typ.
SD3812-R47-R	0.47	0.405	A	2.53	3.89	0.030	2.52
SD3812-1R0-R	1.0	0.845	B	2.00	2.69	0.048	3.64
SD3812-1R2-R	1.2	1.125	C	1.71	2.33	0.066	4.20
SD3812-1R5-R	1.5	1.445	D	1.58	2.06	0.078	4.76
SD3812-2R2-R	2.2	2.205	E	1.32	1.67	0.111	5.88
SD3812-3R3-R	3.3	3.125	F	1.10	1.40	0.159	7.0
SD3812-4R7-R	4.7	4.805	G	0.87	1.13	0.256	8.7
SD3812-6R8-R	6.8	6.845	H	0.80	0.95	0.299	10.4
SD3812-8R2-R	8.2	8.405	I	0.690	0.854	0.406	11.5
SD3812-100-R	10.0	10.125	J	0.662	0.778	0.441	12.6
SD3812-150-R	15.0	15.125	K	0.539	0.636	0.665	15.4
SD3812-220-R	22.0	21.125	L	0.499	0.538	0.776	18.2
SD3812-330-R	33.0	32.805	M	0.399	0.432	1.212	22.7
SD3812-470-R	47.0	47.045	N	0.327	0.361	1.879	27.2
SD3812-680-R	68.0	68.445	O	0.269	0.299	2.666	32.8
SD3812-820-R	82.0	80.645	P	0.259	0.276	2.885	36
SD3812-101-R	100.0	99.405	Q	0.217	0.248	4.090	39
SD3812-151-R	150.0	149.645	R	0.178	0.202	6.130	43
SD3812-221-R	220.0	218.405	S	0.160	0.167	7.585	59
SD3814-R47-R	0.47	0.360	A	2.81	4.44	0.020	2.16
SD3814-R82-R	0.82	0.752	B	2.18	3.06	0.033	3.12
SD3814-1R2-R	1.2	1.001	C	1.85	2.67	0.046	3.60
SD3814-1R5-R	1.5	1.286	D	1.76	2.35	0.051	4.08
SD3814-2R2-R	2.2	1.962	E	1.43	1.90	0.077	5.04
SD3814-3R3-R	3.3	2.781	F	1.21	1.60	0.093	6.0
SD3814-4R7-R	4.7	4.276	G	1.06	1.29	0.141	7.4
SD3814-6R8-R	6.8	6.768	H	0.87	1.03	0.207	9.4
SD3814-8R2-R	8.2	8.228	I	0.753	0.930	0.279	10.3
SD3814-100-R	10.0	9.830	J	0.713	0.851	0.311	11.3
SD3814-150-R	15.0	14.453	K	0.574	0.702	0.481	13.7
SD3814-220-R	22.0	21.186	L	0.519	0.580	0.589	16.6
SD3814-330-R	33.0	32.151	M	0.418	0.471	0.908	20.4
SD3814-470-R	47.0	47.210	N	0.346	0.388	1.322	24.7
SD3814-680-R	68.0	67.324	O	0.285	0.325	1.951	29.5
SD3814-820-R	82.0	81.101	P	0.270	0.296	2.174	32
SD3814-101-R	100.0	98.794	Q	0.228	0.268	3.048	36
SD3814-151-R	150.0	149.026	R	0.191	0.219	4.359	44
SD3814-221-R	220.0	217.342	S	0.170	0.181	5.480	53
SD3814-331-R	330.0	326.812	T	0.136	0.148	8.59	65
SD3814-471-R	470.0	470.031	U	0.111	0.123	12.85	78
SD3814-681-R	680.0	680.320	V	0.100	0.102	15.78	94

(1) Test Parameters: 100 kHz, 0-100 Vrms, 0.0 Adc.
 (2) RMS current for an approximate ΔT of 40 °C without core loss. It is recommended that the temperature of the part not exceed +125 °C. Derating is necessary for AC current.
 (3) Peak current for approximately 30% rolloff at +20 °C.

(4) DCR limits @ +20 °C.
 (5) Applied Volt-Time product (V-us) across the inductor at 100 kHz necessary to generate a core loss equal to 10% of the total losses for 40 °C temperature rise. De-rating of the Irms is required to prevent excessive temperature rise.

Dimensions- mm

SD3812

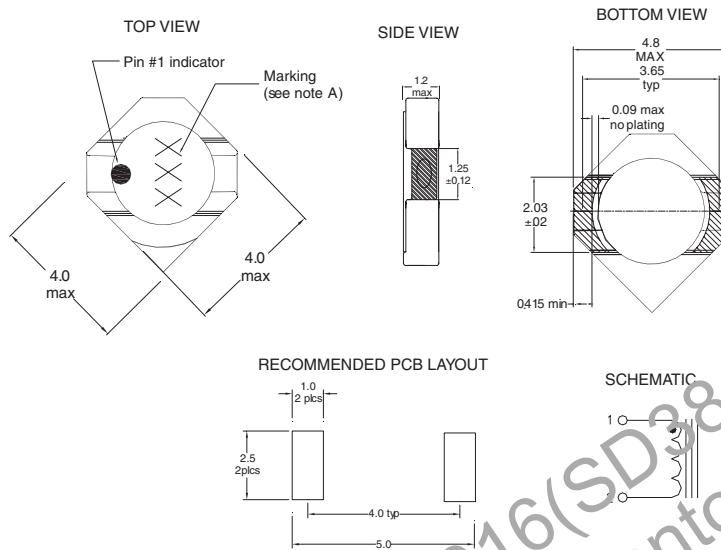

Note A: 3 digit marking. First digit indicates inductance value per chart above.
 Second digit indicates bi-weekly date code.
 Third digit of year produced. Box indicates SD3814 part.
 Do not route traces or vias underneath the inductor

SD3814

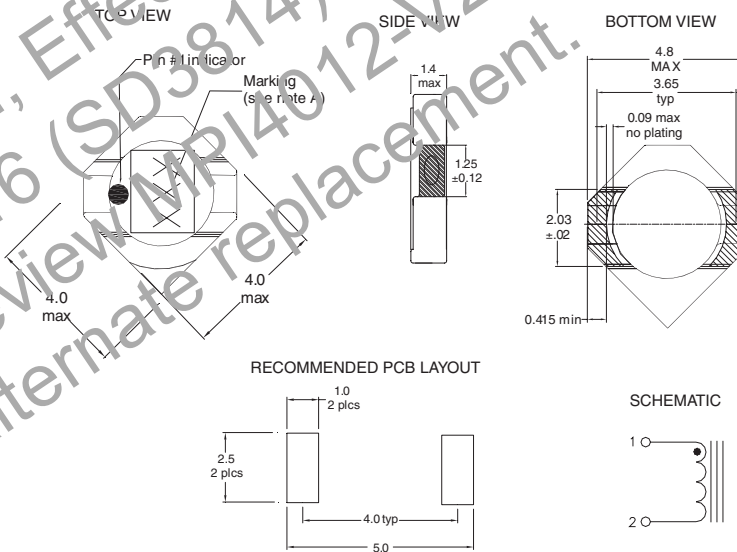

Note A: 3 digit marking. First digit indicates inductance value per chart above.
 Second digit indicates bi-weekly date code.
 Third digit of year produced. Box indicates SD3814 part.
 Do not route traces or vias underneath the inductor

Packaging information- mm

A0=5.1mm
B0=4.6mm
K0=1.6mm

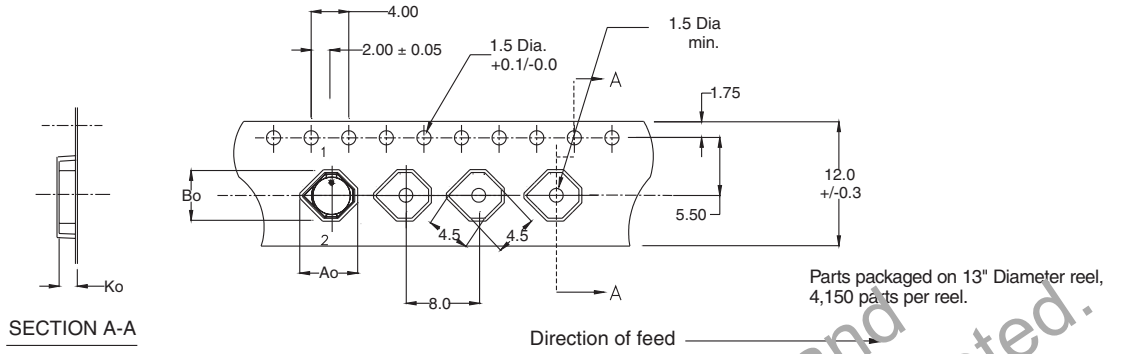

Core loss

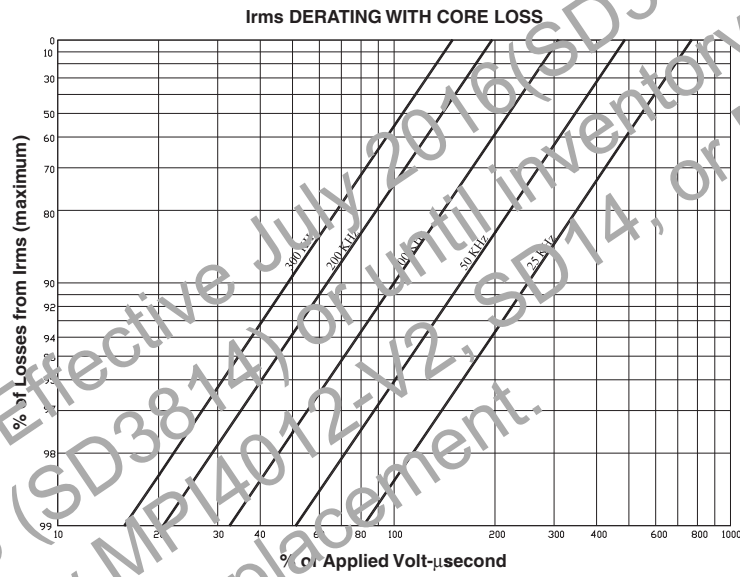

Inductance characteristics

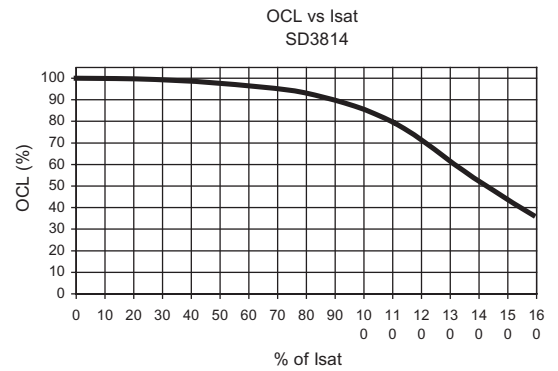
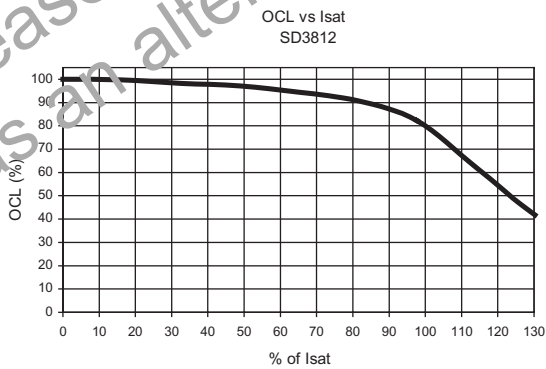

Solder Reflow Profile

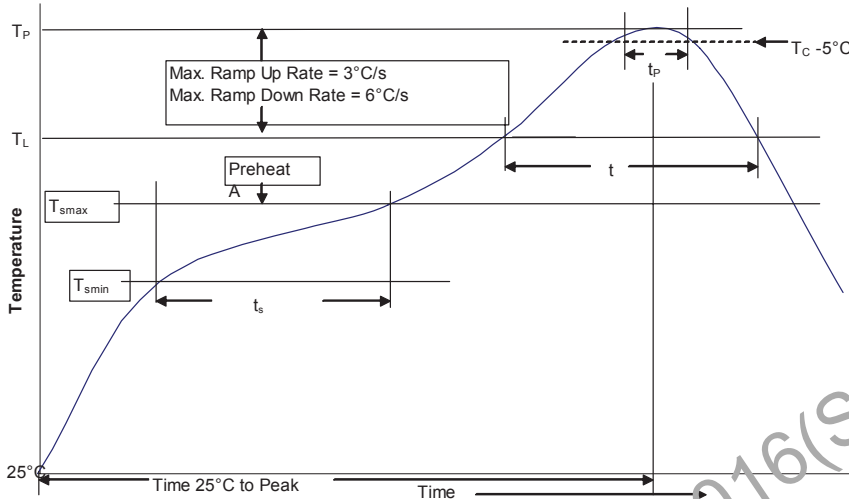

Table 1 - Standard SnPb Solder (T_C)

Package Thickness	Volume mm^3 <350	Volume mm^3 ≥ 350
<2.5mm	235°C	220°C
$\geq 2.5\text{mm}$	220°C	220°C

Table 2 - Lead (Pb) Free Solder (T_C)

Package Thickness	Volume mm^3 <350	Volume mm^3 350 - 2000	Volume mm^3 ≥ 2000
<1.6mm	260°C	260°C	260°C
1.6 - 2.5mm	260°C	250°C	245°C
>2.5mm	250°C	245°C	245°C

Reference JDEC J-STD-020

Profile Feature	Standard SnPb Solder	Lead (Pb) Free Solder
Preheat and Soak	<ul style="list-style-type: none"> Temperature min. (T_{smin}) 100°C Temperature max. (T_{smax}) 150°C Time (T_{smin} to T_{smax}) (t_s) 60-120 Seconds 	<ul style="list-style-type: none"> Temperature min. (T_{smin}) 150°C Temperature max. (T_{smax}) 200°C Time (T_{smin} to T_{smax}) (t_s) 60-120 Seconds
Average ramp up rate T_{smax} to T_P	3°C/ Second Max.	3°C/ Second Max.
Liquidous temperature (T_L)	183°C	217°C
Time at liquidous (t_L)	60-150 Seconds	60-150 Seconds
Peak package body temperature (T_P)*	Table 1	Table 2
Time (t_p)** within 5°C of the specified classification temperature (T_C)	20 Seconds**	30 Seconds**
Average ramp-down rate (T_P to T_{smax})	6°C/ Second Max.	6°C/ Second Max.
Time 25°C to Peak Temperature	6 Minutes Max.	8 Minutes Max.

*Tolerance for peak profile temperature (T_P) is defined as a supplier minimum and a user maximum.

**Tolerance for time at peak profile temperature (t_p) is defined as a supplier minimum and a user maximum.

Life Support Policy: Eaton does not authorize the use of any of its products for use in life support devices or systems without the express written approval of an officer of the Company. Life support systems are devices which support or sustain life, and whose failure to perform, when properly used in accordance with instructions for use provided in the labeling, can be reasonably expected to result in significant injury to the user.

Eaton reserves the right, without notice, to change design or construction of any products and to discontinue or limit distribution of any products. Eaton also reserves the right to change or update, without notice, any technical information contained in this bulletin.

Eaton
Electronics Division
1000 Eaton Boulevard
Cleveland, OH 44122
United States
www.eaton.com/electronics

© 2017 Eaton
All Rights Reserved
Printed in USA
Publication No. 4318
October 2017

Eaton is a registered trademark.

All other trademarks are property of their respective owners.